

ALG-7 WB / ALG-72 WB AIRLESS SPRAY GUN

GB Before use, adjustment or maintenance, it is important to read this instruction manual very carefully. This manual must be stored in a safe place for any future reference that may be necessary.

This **ANEST IWATA** Airless spray guns kit complies to ATEX regulations 94/9/EC.

Protection level: II 2 G X Suitable for using Zones 1 and 2.





X marking: Any static electricity discharge from the Airless spray gun is to be diverted to the ground via the conductive air hose as stipulated.

IMPORTANT

This Airless spray gun should be operated only by an adequately trained operator, for safe use and maintenance of the equipment. Any misuse or handling other than those indicated in this Instruction Manual is not covered by guarantee. ANEST IWATA disclaims all responsibility for any accident or damage caused by failure to observe the operational and safety procedures as from this manual. In the interest of user friendliness, this manual contains information in a brief and concise form.

For any additional information you may require regarding Airless spray guns operations, or if any missing parts or any damage during transportation is found, please contact your nearest ANEST IWATA Company (see last cover page).

Be sure to observe warnings and cautions in this instruction manual.
If not, it can cause paint ejection and serious bodily injury by drawing organic solvent.
Be sure to observe following  marked items which are especially important.

 WARNING	Indicates a potentially hazardous situation which, if not avoided, may result in serious injury or loss of life.
 CAUTION	Indicates a potentially hazardous situation which, if not avoided, may result in minor or moderate injury or property damage.
IMPORTANT	Indicates notes which we ask you to observe. The safety precautions in this instruction manual are the minimum necessary conditions. Follow national and local regulations regarding fire prevention, electricity and safety as well as your own company regulations.

IMPORTANT SPECIFICATIONS

Max. Pressure:	250 bar (3600 PSI)	Max. Temperature:	
Noise Level (LAeqT)	62.9 dB (A)	Atmosphere	5 ~ 40 °C
Spray conditions:	Used nozzle tip NT-3005	Air and fluid	5 ~ 43 °C
	Fluid pressure 100 bar (1440 PSI)		
	Tested with water	Measuring point:	1m backwards from gun, 1.6 m height

TECHNICAL SPECIFICATIONS

Model	Max. Operating pressure bar (PSI)	Use	Fluid Output ml/min.	Fluid Hose connection	Filter	Mass g (lbs)
ALG-7 WB	250 (3600)	General	Ref. to 4. selection of nozzle tip according to kind of paint	G 1/4"	100 mesh (built in)	440 (0.97)
ALG-72 WB						415 (0.91)

Manufactured by:

ANEST IWATA Corporation 3176, Shinyoshida-cho, Kohoku-ku, Yokohama, 223-8501 Japan



ANEST IWATA Europe S.r.l.
46, Corso Vigevano 10155, Torino Italy
Direct Tel. +39 011 - 24 80 868
Fax +39 011 - 22 74 406
info@anest-iwataeu.com
www.anest-iwataeu.com



ANEST IWATA Italia S.r.l.
46, Corso Vigevano 10155, Torino (Italy)
Tel. diretto +39 011 - 24 80 868 - Fax +39 011 - 85 19 44
info@anest-iwata.it www.anest-iwata.it

ANEST IWATA Europe S.r.l.
SUCURSAL ESPAÑA Y PORTUGAL
Avda. del Maresme, 44-46 Planta 2 OF. 25 / 08918 - Badalona (Barcelona)
Tel. +34 933 20 59 93 - Fax. +34 933 20 55 64 -
info@anest-iwata.es www.anest-iwata.es

ANEST IWATA Europe S.r.l.
NIEDERLASSUNG DEUTSCHLAND
Dorfäckerstr. 25, 74248 Ellhofen
Telefon: +49 (0)7134- 917368 - Fax: +49 (0)7134 - 917378
Handy: +49 (0)172 - 62 74 542
info@anest-iwata.de www.anest-iwata.de

European Sales Branches:

ANEST IWATA Scandinavia AB.
Ögärdesvägen 6C, 433 30 PARTILLE
Tel. +46 (0)31 - 340 28 60 - Fax +46 (0)31 - 340 28 69
info@anest-iwata.se www.anest-iwata.se

ANEST IWATA France S.A.
25 rue de Madrid - BP 7405 38074 St Quentin Fallavier
Tél. +33 (0)4 - 74 94 59 69 - Fax +33 (0)4 - 74 94 34 39
info@anest-iwata.fr www.anest-iwata.fr

ANEST IWATA U.K. Ltd.
Unit 10 Little End Road - Eaton Socon
St. Neots - CAMBRIDGESHIRE
PE19 8JH
Tel.: +44 (0) 1480 405419 Fax: +44 (0) 1480 217610
enquiries@anest-iwata.co.uk www.anest-iwata.co.uk

SPARE PARTS LIST

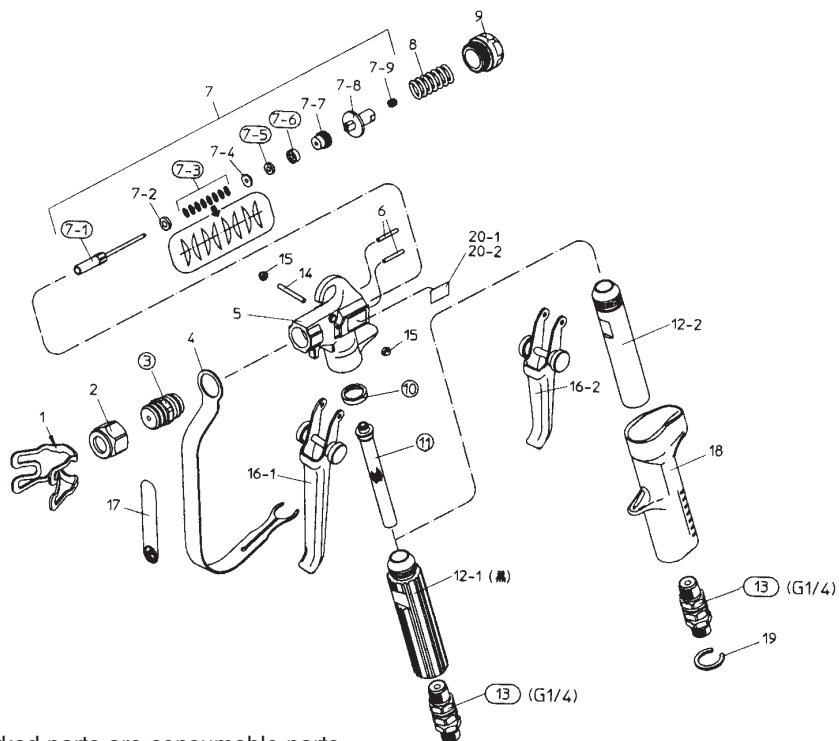

● Marked parts are consumable parts

DESCRIPTION	REF.PART
HAND GUARD	1
NOZZLE HOLDER	2
NOZZLE GLAND SET	3 ●
SAFETY GUARD	4
GUN BODY	5
NEEDLE SEAT	6
NEEDLE SET	7
NEEDLE BAR SET	7-1 ●
CONICAL SPRING HOLDER	7-2
CONICAL SPRING WASHER	7-3 ●
PACKING HOLDER	7-4
SUB PACKING	7-5 ●
NEEDLE PACKING	7-6 ●
NEEDLE PACKING SEAT	7-7
NEEDLE SPRING HOLDER	7-8
SCREW	7-9
NEEDLE SPRING	8
NEEDLE SPRING SEAT	9

DESCRIPTION	REF.PART
PACKING	10 ●
FILTER SET	11 ●
HANDLE (grooved, black)	12-1 for ALG7 WB
HANDLE (round, silver)	12-2 for ALG72 WB
UNIVERSAL JOINT (G 1/4")	13 ●
TRIGGER STUD	14
HEX. CAP NUT	15
TRIGGER SET	16-1 ALG 7 WB
TRIGGER SET	16-2 ALG 72 WB
CAUTION PLATE	17
OUTER HANDLE	18 ALG 72 WB
SNAP RING	19 ALG 72 WB
NAME PLATE	20-1 ALG 7 WB
NAME PLATE	20-2 ALG 72 WB



OTHER PRECAUTIONS

- Never alter this Airless spray gun.**
If done, it can cause insufficient performance and failure.
- Enter working areas of other equipment (robots, reciprocators, etc.) after machines are turned off.**
If not, contact with them can cause injury.
- Never spray foods or chemicals through this gun.**
If done, it can cause accident by corrosion of fluid passages or adversely affect health by mixed foreign matter.
- Securely connect fluid hose.**
If hose is disconnected during operation, hazardous hose movement and paint ejection will cause severe bodily injury.
- If something goes wrong, immediately stop operation and find the cause. Do not use again until you have solved the problem.**

NAME OF COMPONENTS AND CHECKING THE PRODUCT

ALG 7 WB

NOZZLE HOLDER

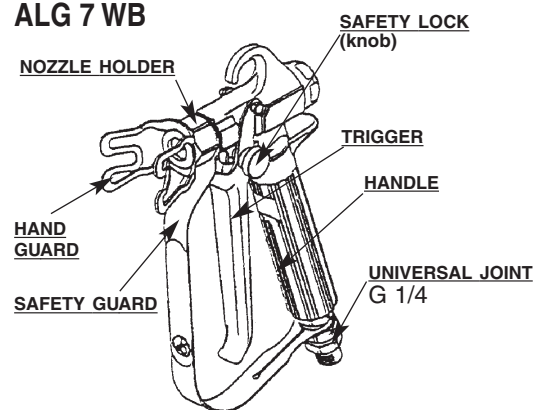

ALG 72 WB

BRUSH FOR CLEANING

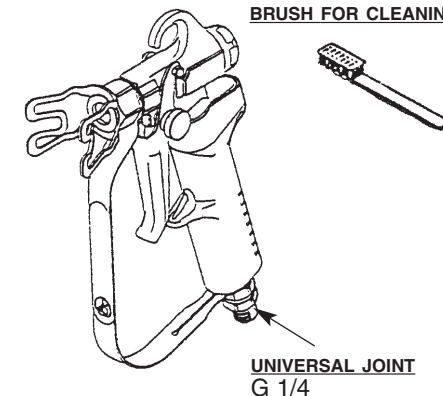

- When you open the package, be sure to check that all goods are included and are in good condition.
- If there is any damage or missing components, do not use the product to avoid danger and immediately contact the distributor who sold it to you.
- Always keep caution plates (warning display) in good condition and clean. If they are damaged or missing, replace with new ones.

PAINTING JOB

CONNECT FLUID HOSE



WARNING

Securely connect fluid hose. When paint leaks, never try to stop it by hand / In that case, stop pump immediately and reduce paint pressure down to 0 pressure.
Be sure to use fluid hose with built-in ground wire in order to connect ground.



CAUTION

Before using a new Airless spray gun, clean inside of the new Airless spray gun. If not, rust preventive oil inside airless spray gun can cause painting failure.

FITTING OR REMOVING NOZZLE TIP OR FREE PATTERN TIP (each tip optional).

*Refer to 4 and prepare nozzle tip separately.



WARNING

Be sure to stop pump, reduce fluid pressure down to 0 pressure and securely apply safety lock of Airless spray gun before you fit or remove nozzle tip.

WHEN USING NOZZLE TIP

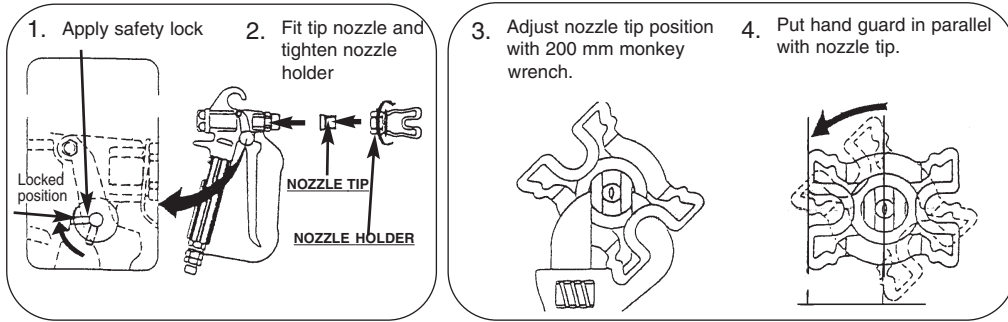

WHEN USING FREE PATTERN TIP

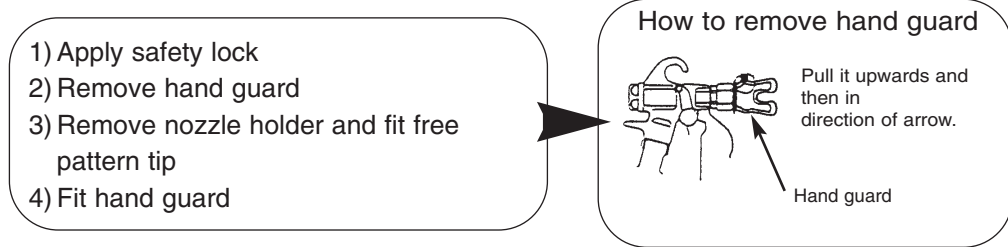

PAINTING JOB



WARNING

During painting, be sure to wear protective cover such as glasses, mask or gloves to avoid serious injury caused by paint or solvent which might enter your eyes or you might inhale.



ATTENTION

As fluid pressure increases, paint mist becomes finer and finishing becomes better. But on the other hand, high pressure can be dangerous and precipitate corrosion of equipment and nozzle tip. Adjust pressure as low as possible as far as finish is satisfactory.

CLEANING AND MAINTENANCE

Fully clean after job is finished in order to get longer lifetime and good performance at next job.

WARNING

During painting, be sure to wear protective cover such as glasses, mask or gloves to avoid serious injury caused by paint or solvent which might enter your eyes or you might inhale.

Be sure to stop pump and reduce fluid pressure down to 0 pressure before disassembling Airless spray gun.

Only an experienced person who is fully conversant with the equipment can do maintenance and inspection.



CAUTION

Never use commercial or other parts instead of ANEST IWATA original spare parts.

Process	Where to clean	How to clean	Remarks
1	nozzle tip	Remove nozzle tip from Airless spray gun and clean it.	
2	inside of gun body	Clean inside of Airless spray gun with cleaning liquid which is compatible with paint being used.	
3	filter set	1. Remove No.12 handle from gun body. 2. Remove and clean No.11 filter set.	

SELECTION OF NOZZLE TIP ACCORDING TO KIND OF PAINT

<Numbering system>

Pattern width 25 cm at 30cm spray distance.

Fluid output 0.7ml/sec/cm of width at fluid pressure 98 bar/1421PSI.

NT - 25 07

Use nozzle tip with large figures of last 2 digits when you spray paints of high viscosity or easily clogged.

USAGE	KIND OF PAINT	MODEL (NT-0000)	REMARKS
Shipbuilding	Rubber chloride paint, Ship-bottom paint	2507-4009	Commonly used
	Tar epoxy paint	3011-4013	Last two digits are large due to high viscosity.
	Zinc rich paint (organic)	2507-4009	Commonly used
	Zinc rich paint (non-organic)	3019-4016	Last two digits are large because it is easy to clog.
Construction	Water base (emulsion paint), Ready mixed paint	2505-4007	Commonly used
Steel frame	Anti-corrosive paint	1507-2513	First two digits are small, and last two digits are large, for angle iron.
Woodwork	Clear lacquer, Synthetic resin varnish	1503-3005	Commonly used
Common metal	Lacquer, Melamine	1504-4007	Commonly used

PROBLEMS AND REMEDIES

IMPORTANT : As for * marked items, ask our distributor to remedy it for you. Incorrect remedy cannot achieve satisfactory performance.

Problem	Cause	Remedies
Paint does not come out.	Nozzle tip is clogged.	Clean nozzle tip and remove foreign matter from hole by needle.
	Paint is not fed.	Inspect pump.
	Filter set [11] is completely clogged.	Clean or replace.
Paint comes out weakly.	Pump pressure is low.	Increase pump pressure.
	Filter set [11] is clogged.	Clean or replace.
	Nozzle tip is worn or number of nozzle tip is too large. (Pump capacity is small compared with nozzle tip being used.)	Replace with new tip or proper sized tip.
Paint does not stop smoothly. (Paint leaks from the gun tip).	Pump pressure is too high.	Reduce paint pressure down to 250 bar (3.600 PSI)
	Paint sticks to needle packing [7-9].	Disassemble, clean or replace parts.*
	Paint sticks to needle seat [6].	Disassemble, clean or replace parts.*
	Seat between needle bar set [7-1] and nozzle gland set [3] is worn.	Disassemble, clean or replace parts.*
Paint leaks from needle spring seat [9] or needle seat [6].	Needle packing seat [7-7] is loose.	Tighten needle spring holder [7-8].
	Wear or damage of needle packing [7-6]	Disassemble, clean or replace parts.*
	Wear or damage of needle bar set [7-1]	Disassemble, clean or replace parts.*
Paint leaks from universal joint [13]	Wear of packing in universal joint	Replace universal joint.